

80x80x08mm

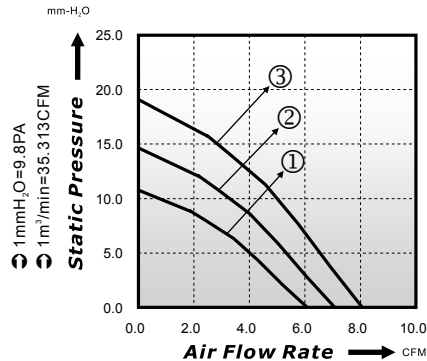

### ■ P-Q Curve (At Rated Voltage)



### ■ Dimensions Drawing

Unit: (mm)

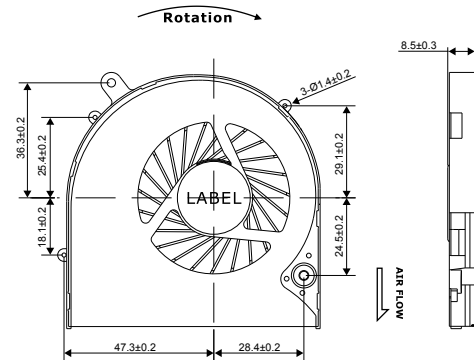

Model No	Bearing (*)	Rated Voltage (VDC)	Rated Current (A)	Power Consumption (Watts)	Speed (rpm)	Air Flow (CFM)	Static Pressure (mmH <sub>2</sub> O)	Noise (dBA)	Curve
EBD08008-05L*	○ ⊖	5	0.35	1.75	3000	6.09	10.78	40.0	1
EBD08008-05M*	○ ⊖	5	0.50	2.50	3500	7.08	14.65	42.8	2
EBD08008-05H*	○ ⊖	5	0.70	3.50	4000	8.07	19.09	47.3	3
EBD08008-12L*	○ ⊖	12	0.40	4.80	3000	6.09	10.78	40.0	1
EBD08008-12M*	○ ⊖	12	1.40	16.80	3500	7.08	14.65	42.8	2
EBD08008-12H*	○ ⊖	12	2.40	28.80	4000	8.07	19.09	47.3	3

\* Bearing Type: ○ Sleeve ● Two Ball ⊖ Hydro-Dynamic